

Стандартные размеры не резьбовой шпильки для конденсаторной сварки

Не резьбовые шпильки (Штифты) тип UT

EN ISO 13918

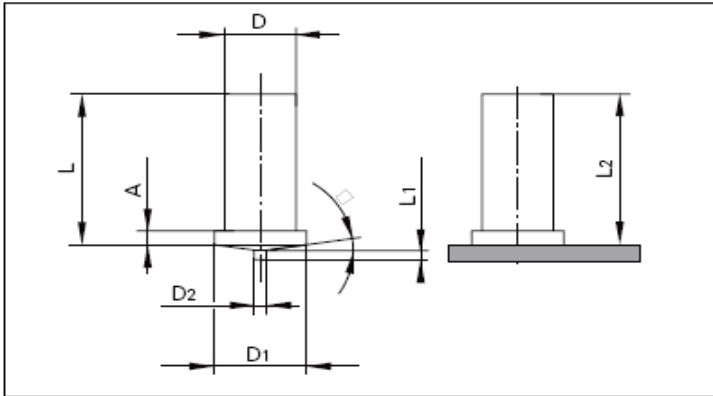

D ±0.1	L +0.6	D1 ±0.2	D2 ±0.08	L1 ±0.05	A	L2	□ ±1°
Ø3	See dimensions	4.5	0.60	0.55	0.7-1.4	~L -0.3	3°
Ø4		5.5	0.65				
Ø5		6.5	0.75	0.80	0.8-1.4		
Ø6		7.5					

26-27



Dimension D x L	Order No.	Dimension D x L	Order No.
3 x 6	B06005	6 x 10	B06305
3 x 8	B06010	6 x 12	B06310
3 x 10	B06015	6 x 15	B06315
3 x 12	B06020	6 x 20	B06325
3 x 15	B06025	6 x 25	B06330
3 x 20	B06035	6 x 30	B06335
3 x 25	B06040	6 x 35	B06345
		6 x 40	B06350
4 x 8	B06055	7.1 x 10	B06399
4 x 10	B06065	7.1 x 12	B06400
4 x 12	B06075	7.1 x 15	B06405
4 x 15	B06080	7.1 x 20	B06410
4 x 20	B06085	7.1 x 25	B06412
4 x 25	B06090	7.1 x 30	B06414
4 x 30	B06095		
4 x 35	B06100		
5 x 8	B06205		
5 x 10	B06215		
5 x 12	B06220		
5 x 15	B06225		
5 x 20	B06240		
5 x 25	B06245		
5 x 30	B06250		
5 x 35	B06255		
5 x 40	B06260		

Dimension D x L	Order No.	Dimension D x L	Order No.
3 x 6	B07000	6 x 10	B07305
3 x 8	B07002	6 x 12	B07310
3 x 10	B07005	6 x 15	B07315
3 x 12	B07006	6 x 16	B07316
3 x 15	B07007	6 x 20	B07320
3 x 16	B07008	6 x 25	B07325
3 x 20	B07010	6 x 30	B07330
3 x 25	B07015	6 x 35	B07335
		6 x 40	B07340
4 x 8	B07105	6 x 45	B07345
4 x 10	B07110	6 x 50	B07350
4 x 12	B07115		
4 x 15	B07120	7.1 x 10	B07400
4 x 16	B07121	7.1 x 12	B07405
4 x 20	B07125	7.1 x 15	B07410
4 x 25	B07130	7.1 x 16	B07411
4 x 30	B07132	7.1 x 20	B07415
4 x 35	B07135	7.1 x 25	B07417
		7.1 x 30	B07420
5 x 8	B07205	7.1 x 35	B07422
5 x 10	B07210	7.1 x 40	B07424
5 x 12	B07215	7.1 x 45	B07426
5 x 15	B07220	7.1 x 50	B07428
5 x 16	B07221	7.1 x 55	B07430
5 x 20	B07225		
5 x 25	B07230		
5 x 30	B07235		
5 x 35	B07240		
5 x 40	B07245		

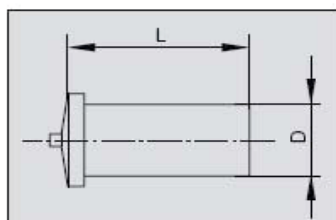

Welding pins are generally suitable for manual and fully automatic

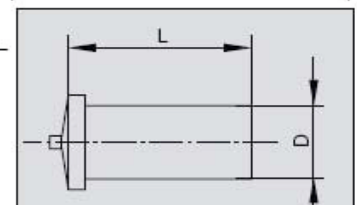

Welding pins are generally suitable for manual and fully automatic

welding pins are generally suitable for manual and fully automatic feeding.



Welding pins are generally suitable for manual and fully automatic feeding.



Сварочные шпильки без резьбы для конденсаторной сварки

Тип PT, Материал: St 37-3 омедненный
(4.8 соответствующий для сварки)

Сварочные шпильки без резьбы для конденсаторной сварки

Тип PT, Материал: Сталь нержавеющая 1.4301/1.4303 (V2a)
(A2-50 соответствующий для сварки)

28-29



Dimension D x L	Order No.	Dimension D x L	Order No.
3 x 6	B09000	5 x 8	B09055
3 x 8	B09002	5 x 10	B09060
3 x 10	B09005	5 x 15	B09062
3 x 12	B09006	5 x 20	B09064
3 x 15	B09007	5 x 25	B09066
3 x 20	B09011	5 x 30	B09065
4 x 8	B09010	6 x 10	B09100
4 x 10	B09015	6 x 15	B09102
4 x 15	B09020	6 x 20	B09104
4 x 20	B09023	6 x 25	B09105
4 x 25	B09025		

Dimension D x L	Order No.	Dimension D x L	Order No.
3 x 6	B08000	6 x 10	B08305
3 x 8	B08005	6 x 12	B08310
3 x 10	B08010	6 x 15	B08315
3 x 12	B08012	6 x 20	B08320
3 x 15	B08015	6 x 25	B08325
3 x 20	B08025	6 x 30	B08326
		6 x 35	B08327
4 x 8	B08115	7.1 x 10	B08398
4 x 10	B08120	7.1 x 12	B08399
4 x 15	B08130	7.1 x 15	B08400
4 x 20	B08135	7.1 x 20	B08405
4 x 25	B08140	7.1 x 25	B08406
		7.1 x 30	B08407
5 x 8	B08205		
5 x 10	B08210		
5 x 15	B08220		
5 x 20	B08225		
5 x 25	B08230		
5 x 30	B08235		

Welding pins are generally suitable for manual and fully automatic feeding.

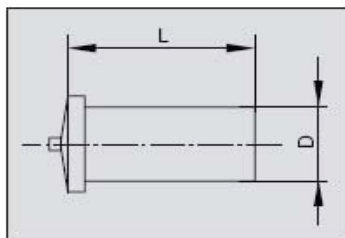

Welding pins are generally suitable for manual and fully automatic feeding.

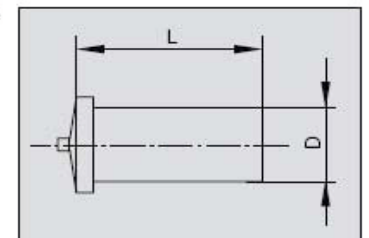

ВЕКТОР ГРУПП 

117405 г. Москва ул. Дорожная д. 60
тел./факс +7 (495) 787 49 12
e-mail: info@vektor-grupp.ru
сайт : www.vektor-grupp.ru